

WP4500 – Orbital Milling machine **98 – 178" (2500 – 4500mm)**

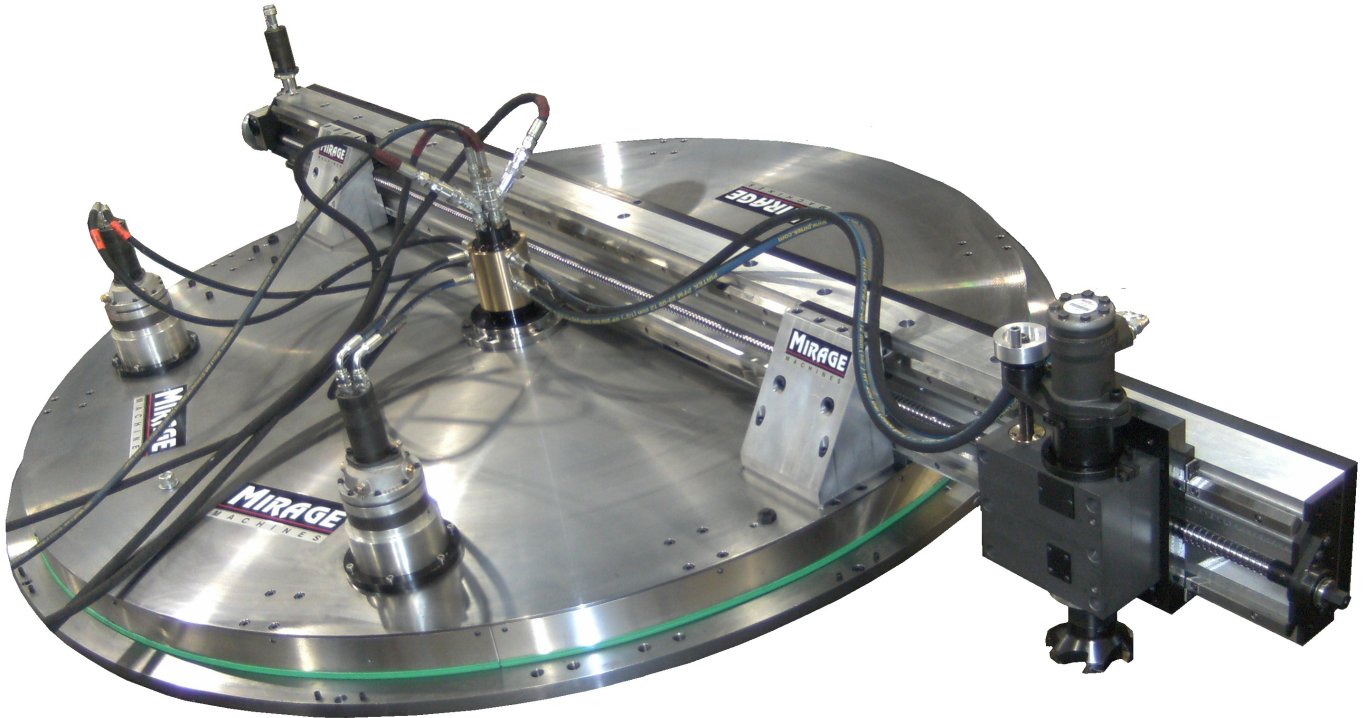

A unique concept for the machining of flanges which provides fast material removal with high accuracy. Specifically developed for the production machining of larger offshore wind turbine rotor blades

- ***Precision preloaded Linear rotary drive***
- ***Adjustable fast set hydraulic clamping***
- ***Anti backlash hydraulic drive***
- ***Radial contour milling feed***

Technical Details

RANGE		
Min. / Max. facing diameter	2500 (98")	4500mm(178")
Min. / Max. clamping diameter	2500 (98")	4000mm(157")
Rotational Drive – hydraulic	5.0Hp	3.7 Kw
Milling spindle – Hydraulic (standard)	5.0 Hp	3.7 Kw
Min. / Max. rotation R.P.M (standard)	0	5
Surface cutting speeds @ max diameter	0 – 1 m/min	0 – 3.5 ft/min
Min / Max Spindle R.P.M (standard)	25	265
Flatness tolerance per 1m/40" diameter	0.05mm	0.002"
Spindle down Feed	80mm	3.15"
Hydraulic supply @ 1050 psi (70 bar)	60 L/min	16 gal/min

FEED RATES		
Standard cutting speed (125mm face)	400mm/min	16" / min

WEIGHTS AND DIMENSIONS		
Machine weight (not including the base)	2976 kgs	6547 lbs
Shipping weight	7107 Kgs	15635 lbs

Shipping dimensions	L - 252cm - (99")	W- 228cm (89")	H- 92cm (36")
Shipping dimensions	L - 321cm - (126")	W- 227cm (89")	H- 236cm (93")

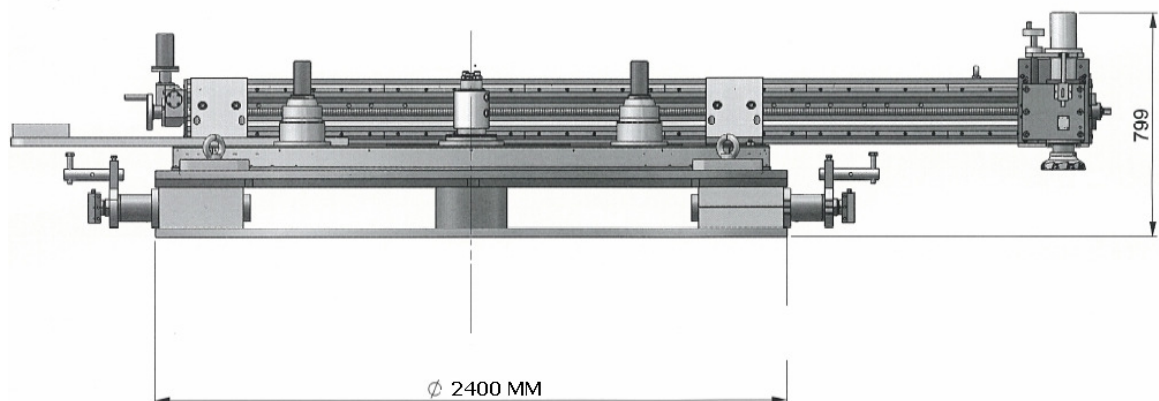

The machine is supplied complete with drive ring, drive motors and reduction gearbox, facing feed /direction gearbox and pick up gearbox, Milling facing arm and 90mm column spindle, internal chuck base assembly, jaw blocks and 8 of clamping jaws - 4 off which are adjustable, toolkit, hose kit and centre distributor, all required bolts and storage / shipping box, CE certificate, Packing list and Manual.

Optional – Production quick install 3 point mounting system, hydraulic trolley power pack

10 Enterprise Way, Jubilee Parkway. DERBY DE21 4BB. UK

Tel: +44 (0)1332 291767 Fax: +44 (0)1332 370356

Email: sales@miragemachines.com www.miragemachines.com



Optional Accessories

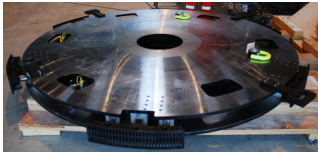

WP3500-6 Hydraulic mounting base - Machine base for production mounting into turbine rotor blades / towers



HYPP60-30- 3ph 15 hp tandem hydraulic power pack 50 lpm / 20 lpm @ 70 bar – 380/440v 3 phase – pendant control

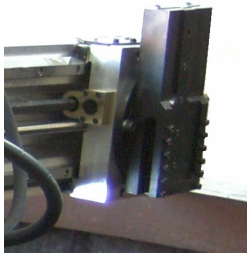

WP6000-9 Single point turning tool post, carriage, tools and drive



WP6000-8 Extended milling spindle – 250mm stroke

NEG0100-9 Swivel head milling carriage and spindle

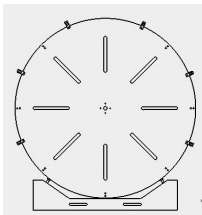

WP6000-15 Tube sheet mounting kit - Mount the WP6000 to tube sheets efficiently



MM1080ie-20 Tube sheet back facing kit - Machine heat exchanger flange back faces in one setup.



MM3000i-12 Eight leg fabricated chucking base 50-110"



Tooling We can supply all inserted face mills and inserts and special form tools on request