

MM610i - Flange Facer **2 - 24" (50 - 610mm)**

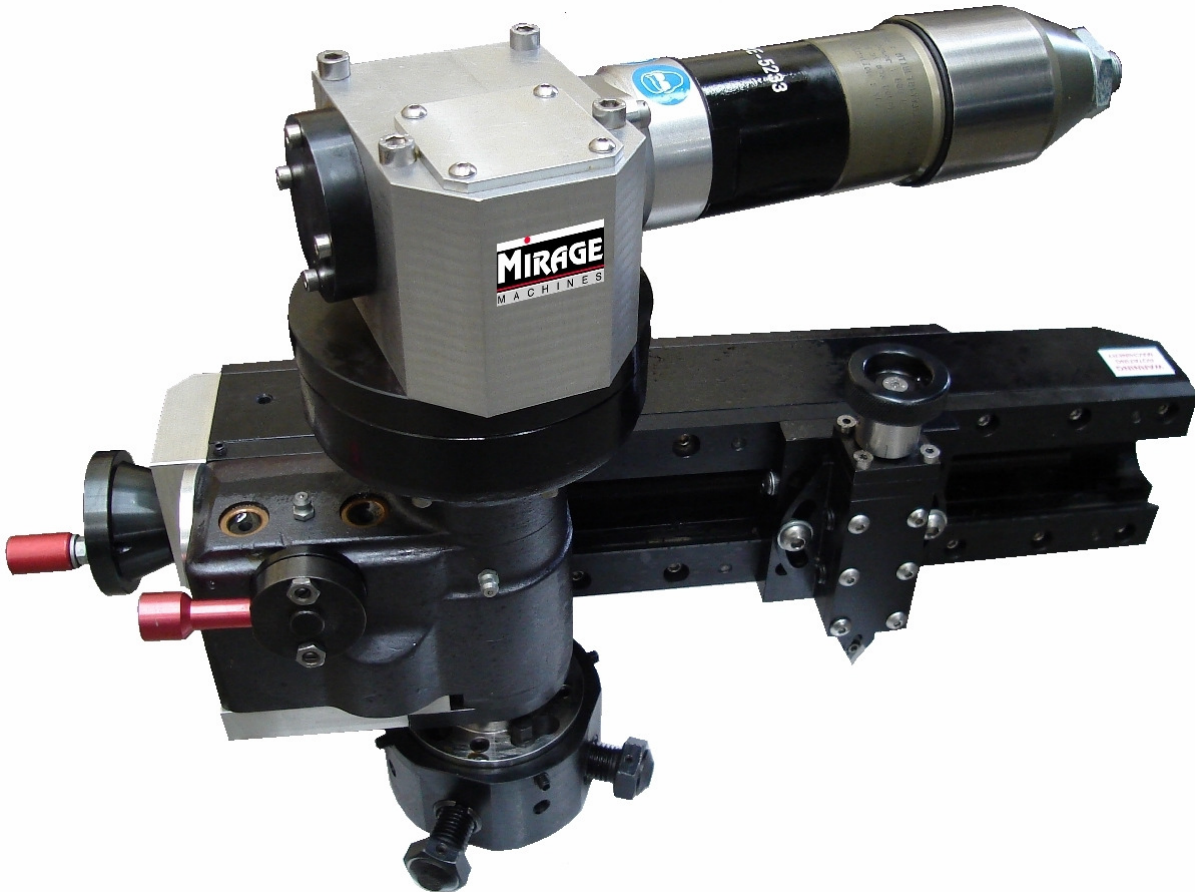

An internally mounted lightweight yet strong flange facing machine for all types of flange facing, seal groove machining, weld prep and counter boring

- ***Lightweight precision construction***
- ***Geared continuous groove facing feeds***
- ***Swivel tool post***
- ***Helical drive for superior surface finish***
- ***Quick set independent base***

Technical Details

| RANGE | | |
|--------------------------------------|------------|-----------|
| Minimum Facing diameter | 50mm | 2" |
| Maximum Facing diameter | 610mm | 24" |
| Minimum Clamping diameter | 50mm | 2" |
| Maximum Clamping diameter | 508mm | 20" |
| Tool post travel | 50mm | 2" |
| R.P.M | Min: 20 | Max: 42 |
| Drive – Pneumatic @ 90 p.s.i (6 bar) | 1.1 Hp | 0.80 Kw |
| Air Consumption / supply required | 42 s.c.f.m | 1.19 m3/m |

| FEED RATES | | |
|---|---------------|----------------|
| Facing feeds (1.75mm pitch feed screw) | 0.12 / 0.48mm | 0.006 / 0.019" |
| Facing feeds (1.25mm pitch feed screw) | 0.08 / 0.32mm | 0.003 / 0.013" |
| Facing feeds (1.0mm pitch feed screw) | 0.06 / 0.24mm | 0.002 / 0.010" |

| WEIGHTS AND DIMENSIONS | | |
|-------------------------------------|--------|---------|
| Machine weight (independent base) | 45 kgs | 99 lbs |
| Shipping weight | 62 kgs | 136 lbs |

| | | | |
|---------------------|------------------|---------------|---------------|
| Shipping dimensions | L - 65cm - (26") | W- 45cm (18") | H- 38cm (15") |
|---------------------|------------------|---------------|---------------|

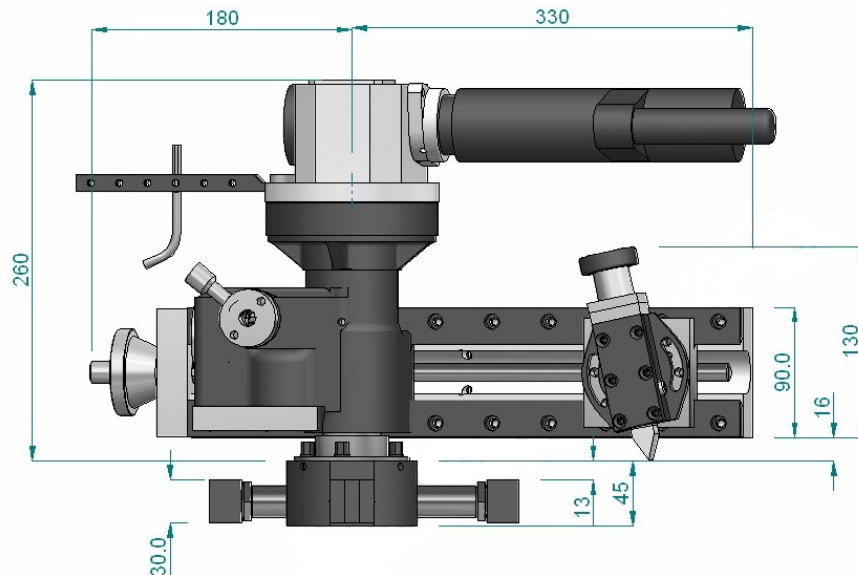

The machine is supplied complete with toolkit including tools and inserts, air filter lubricator and hose connection, all required mounting bases and extensions, storage / shipping box, CE certificate, Packing list and Manual

10 Enterprise Way, Jubilee Parkway. DERBY DE21 4BB. UK

Tel: +44 (0)1332 291767 Fax: +44 (0)1332 370356

Email: sales@miragemachines.com www.miragemachines.com