

## **MM600E - Flange Facer** **0 - 24" ( 0 - 610mm)**

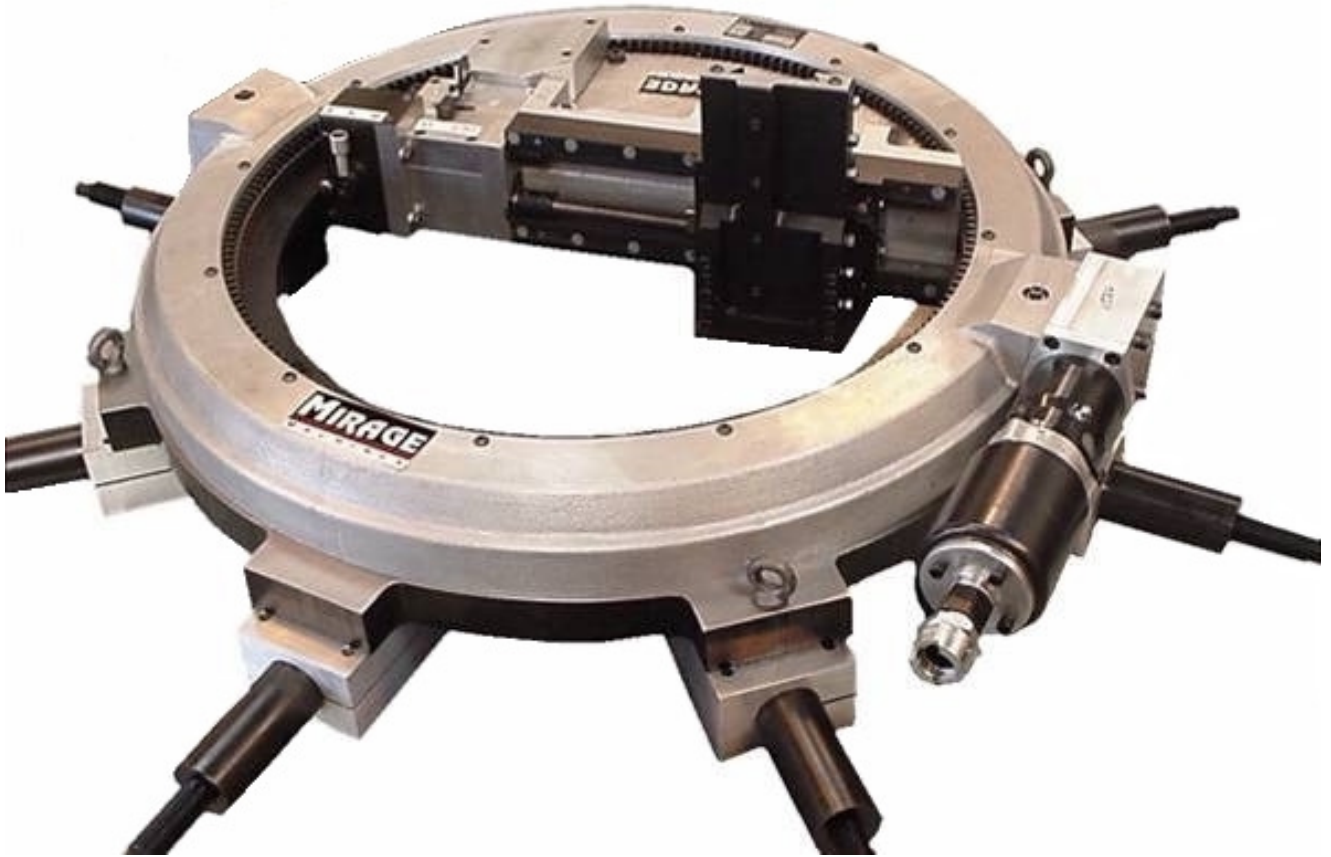

An externally mounted flange facing machine for all types of flange facing, seal groove machining, weld preparation and counter boring

- ***Preloaded cross roller drive ring***
- ***Swivel tool post***
- ***Geared continuous groove facing feeds***
- ***Quick set independent base***
- ***Helical drive for superior surface finish***

# Technical Details

RANGE		
Minimum Facing diameter	0mm	0"
Maximum Facing diameter	610mm	24"
Minimum Clamping diameter	305mm	12"
Maximum Clamping diameter	610mm	24"
Tool post travel	102mm	4"
R.P.M	Min: 15	Max: 33
Drive – Pneumatic @ 90 p.s.i (6 bar)	4.0 Hp	3.0 Kw
Air Consumption / supply required	96 s.c.f.m	2.69 m3/m

FEED RATES		
Facing continuous groove (fine / coarse )	0.20 / 0.80mm	0.008 / 0.032"
Boring feeds (fine / coarse )	0.18 / 0.72mm	0.007 / 0.028"

WEIGHTS AND DIMENSIONS		
Machine weight ( independent base 14kgs)	154 kgs	339 lbs
Shipping weight	265 kgs	583 lbs

Shipping dimensions	L - 100cm - (40")	W- 96cm (38")	H- 43cm (17")
---------------------	-------------------	---------------	---------------

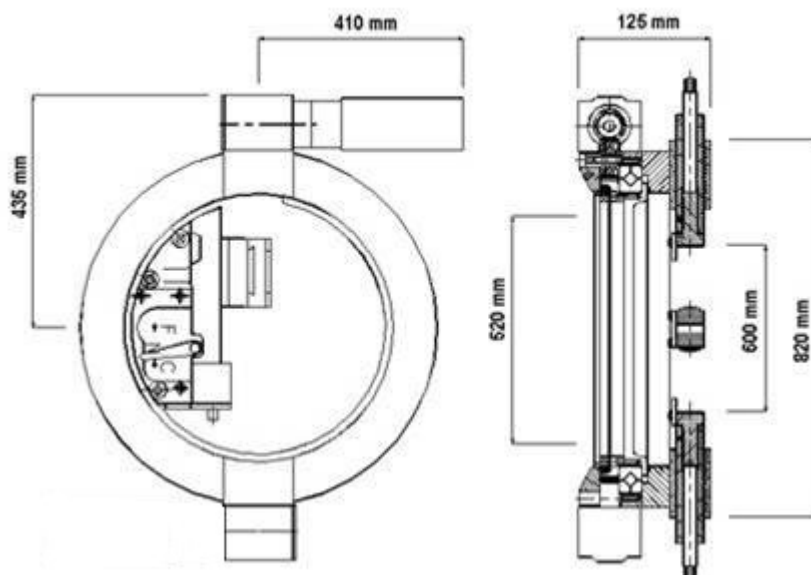

The machine is supplied complete with toolkit including tools and inserts, air filter lubricator and hose connection, all required mounting bases and extensions, storage / shipping box, CE certificate, Packing list and Manual

10 Enterprise Way, Jubilee Parkway. DERBY DE21 4BB. UK

Tel: +44 (0)1332 291767 Fax: +44 (0)1332 370356

Email: [sales@miragemachines.com](mailto:sales@miragemachines.com) [www.miragemachines.com](http://www.miragemachines.com)