

HTM150XL Hot Tapping machine

32" stroke – Ø1/2 - 6" capacity



A version of our HTM machines that have a maximum working pressure capacity of 1480 p.s.i and can Hot tap from Ø1/2 – 6" specifically designed for the water, gas and petrochemical industries .

- ***Manual rotation & feed***
- ***2" NPT connection***
- ***Lightweight construction***
- ***Pressure 102 bar (1480 psi)***

Technical Details

RANGE		
Minimum tapping hole diameter	12mm	1/2"
Maximum tapping hole diameter	152mm	6"
Maximum working pressure	102 bar	1480 p.s.i
Maximum operating temperature	200° C	392° F
Spindle bar travel	760mm	32"
R.P.M (when motor driven)	0	200
Drive - Pneumatic (weight + 4 kgs)	0.9 Hp	0.67Kw
Air supply required @ 90 p.s.i	42 s.c.f.m	1.19 m3/m

FEED RATES		
Feed rate - Manual / revolution	3.0mm	0.118"

WEIGHTS AND DIMENSIONS		
Machine weight	32 kgs	70 lbs
Shipping weight	59 Kgs	130 lbs

Shipping dimensions	L - 212cm - (83")	W- 38cm (15")	H- 26cm (10")
---------------------	-------------------	---------------	---------------

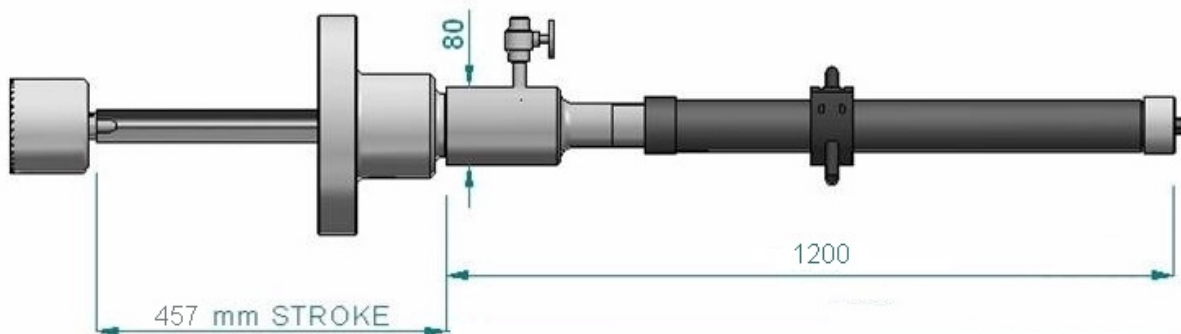

The machine is supplied complete with toolkit, air filter lubricator (when required) and hose connection, all required hole saw adapters and drive plates, storage / shipping box, CE certificate, Packing list and Manual

10 Enterprise Way, Jubilee Parkway. DERBY DE21 4BB. UK

Tel: +44 (0)1332 291767 Fax: +44 (0)1332 370356

Email: sales@miragemachines.com www.miragemachines.com

HTM150XL - Set



Complete Kit for 1/2 - 6" #150 and #300 Hot taps		
Part	Description	Qty
HTM150XL	(1/2" - 6") HOT TAP MACHINE	1
HTM1504	18" STROKE SHORT DRILL SHAFT	1
FLANGE ADAPTERS		
TA2-2	2" NPT THREADED ADAPTER	2
FA2#150	2" #150 FLANGE ADAPTER	1
FA3#150	3" #150 FLANGE ADAPTER	1
FA4#150	4" #150 FLANGE ADAPTER	1
FA6#150	6" #150 FLANGE ADAPTER	1
FA2#300	2" #300 FLANGE ADAPTER	1
FA3#300	3" #300 FLANGE ADAPTER	1
FA4#300	4" #300 FLANGE ADAPTER	1
FA6#300	6" #300 FLANGE ADAPTER	1
STANDARD DRILLS		
HTMD1/2	1/2" STANDARD DRILL	1
HTMD1	1" STANDARD DRILL	1
HTMD11/4	1-1/4" STANDARD DRILL	1
HTMD11/2	1-1/2" STANDARD DRILL	1
HOLE SAW TOOLING		
HTMHSP2	2-3" HOLE SAW HOLDER & PILOT DRILL	1
HTMHSP3	3 -6" HOLE SAW HOLDER & PILOT DRILL	1
HTM1511	3 - 6" HOLE SAW DRIVE PLATE	1
HOLE SAW CUTTERS		
HTMHS2	2" HOT TAP HOLE SAW	1
HTMHS3	3" HOT TAP HOLE SAW	1
HTMHS4	4" HOT TAP HOLE SAW	1
HTMHS6	6" HOT TAP HOLE SAW	1

10 Enterprise Way, Jubilee Parkway. DERBY DE21 4BB. UK
 Tel: +44 (0)1332 291767 Fax: +44 (0)1332 370356
 Email: sales@miragemachines.com www.miragemachines.com