

## **WP2500 – Orbital Milling machine 56 – 98" ( 1400 – 2500mm)**

A unique new concept for the machining of flanges which provides fast metal removal with high accuracy.



- ***Induction hardened 'V' rails***
- ***Precision preloaded Linear rotary drive***
- ***Ball screw feed to minimize backlash***
- ***Adjustable fast set clamping jaws***
- ***Twin hydraulic drive***
- ***Radial contour milling feed***



## WP2500 Technical Details

### RANGE

Min. / Max. clamping diameter (Internal)	1325 (52")	2500mm(98")
Min. / Max. turning diameters (Internal)	1400 (55")	2500mm(98")
Rotational Drive – twin hydraulic (2.2hp)	4.4 Hp	3.28 Kw
Milling spindle – Hydraulic (standard)	5.0 Hp	3.78 Kw
Min. / Max. rotation R.P.M (standard)	0	3
Surface cutting speeds @ max diameter	0 – 56 m/min	0 – 185 ft/min
Standard cutting speed (125mm face)	400mm/min	16" / min
Min / Max Spindle R.P.M (standard)	25	265
Spindle down Feed	80mm	3.125"
Hydraulic supply @ 1050 psi (70 bar)	60 L/min	16 gal/min

### FEED RATES (single point turning option)

Min. / Max Facing feeds (2 off IN / OUT )	0.10 – 0.81mm	0.004" – 0.032"
---	---------------	-----------------

### WEIGHTS AND DIMENSIONS

Machine weight (not including the base)	900 kgs	1980 lbs
Shipping weight (inc. int. / ext. base rings)	1050 Kgs	2310 lbs

Shipping dimensions	L - 220cm - (86")	W- 174cm (68")	H- 58cm (22")
---------------------	-------------------	----------------	---------------

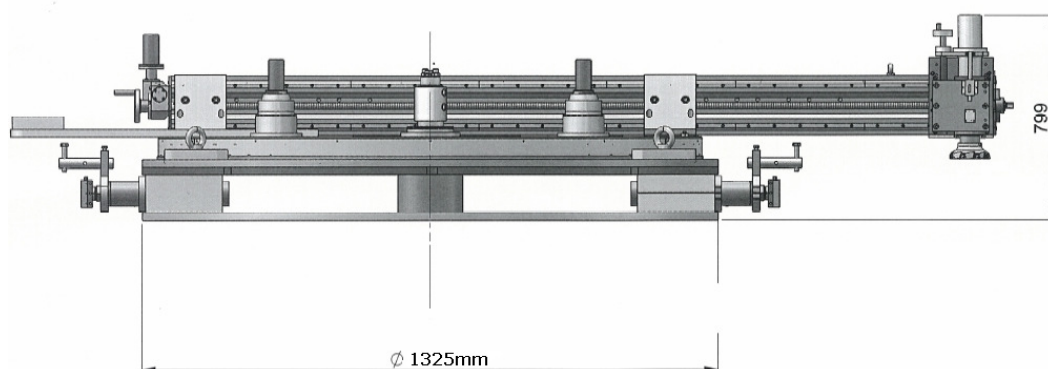

The machine is supplied complete with drive ring, drive motors and reduction gearbox, facing feed /direction gearbox and pick up gearbox, Milling facing arm and 90mm column spindle, internal chuck base assembly, jaw blocks and 8 of clamping jaws - 4 off which are adjustable, toolkit, hose kit and centre distributor, all required bolts and storage / shipping box, CE certificate, Packing list and Manual.

**Optional** – Production quick install 3 point mounting system, hydraulic trolley power pack

10 Enterprise Way, Jubilee Parkway. DERBY DE21 4BB. UK

Tel: +44 (0)1332 291767 Fax: +44 (0)1332 370356

Email: [sales@miragemachines.com](mailto:sales@miragemachines.com) www.miragemachines.com

**MIRAGE**  
M A C H I N E S

**MIRAGE**