

## SL355 High speed slitting head

Ø1.5" - 4" wall thickness

A heavy duty slitting head and slide that can be mounted to a linear or radial track for high speed tight access pipe, tank and stud cutting



- **High metal removal carbide blades**
- **Precision low height slide**
- **Helical geared drive**
- **Compact (right angle drive available)**
- **Can be attached to linear or radial tracks**
- **Fast mount magnets available**

# SL355 Technical Details

# MIRAGE

RANGE		
Maximum wall thickness (180 blade)	40mm	1.5"
Maximum wall thickness (355 blade)	100mm	4"
Spindle travel	100mm	4"
Spindle R.P.M	Min: 200	Max: 2000
Radial track available max radius	5000mm	197"
Linear track available max. length	4000mm	157"
Drive - Hydraulic ( weight + 6 kgs)	5.0 Hp	3.73 Kw
Hydraulic supply required @ 1050 p.s.i	40 L/min	9 gal/min

FEED RATES		
Linear or radial feed rate (6mm D.O.C)	500mm/min	20"/min
Feed rate - Manual / revolution down feed	1.5mm	0.060"

WEIGHTS AND DIMENSIONS		
Machine weight	30 kgs	66 lbs
Shipping weight	50 Kgs	110 lbs

Shipping dimensions	L - 40cm - (16")	W- 40cm (16")	H- 25cm (10")
---------------------	------------------	---------------	---------------

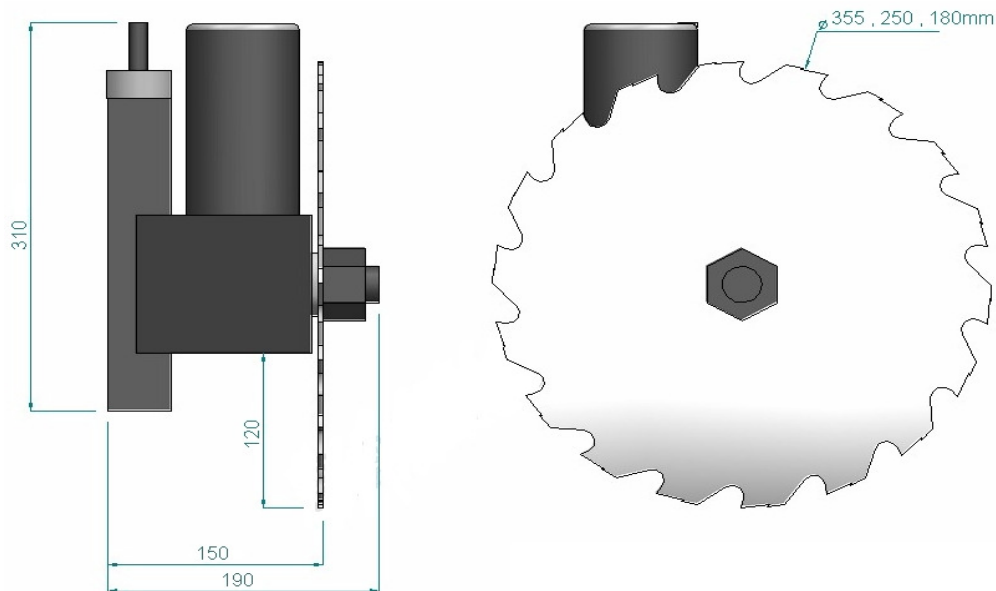

The machine is supplied complete with toolkit, air filter lubricator (when required) and hose connection, required blade, storage / shipping box, CE certificate, Packing list and Manual

10 Enterprise way, Jubilee Parkway. DERBY DE21 4BB. UK

Tel: +44 (0)1332 291767 Fax: +44 (0)1332 370356

Email: [sales@miragemachines.com](mailto:sales@miragemachines.com) [www.miragemachines.com](http://www.miragemachines.com)

