

MSF300 - 1220 Pipe Cutting and Bevelling Ø4 - 48" capacity

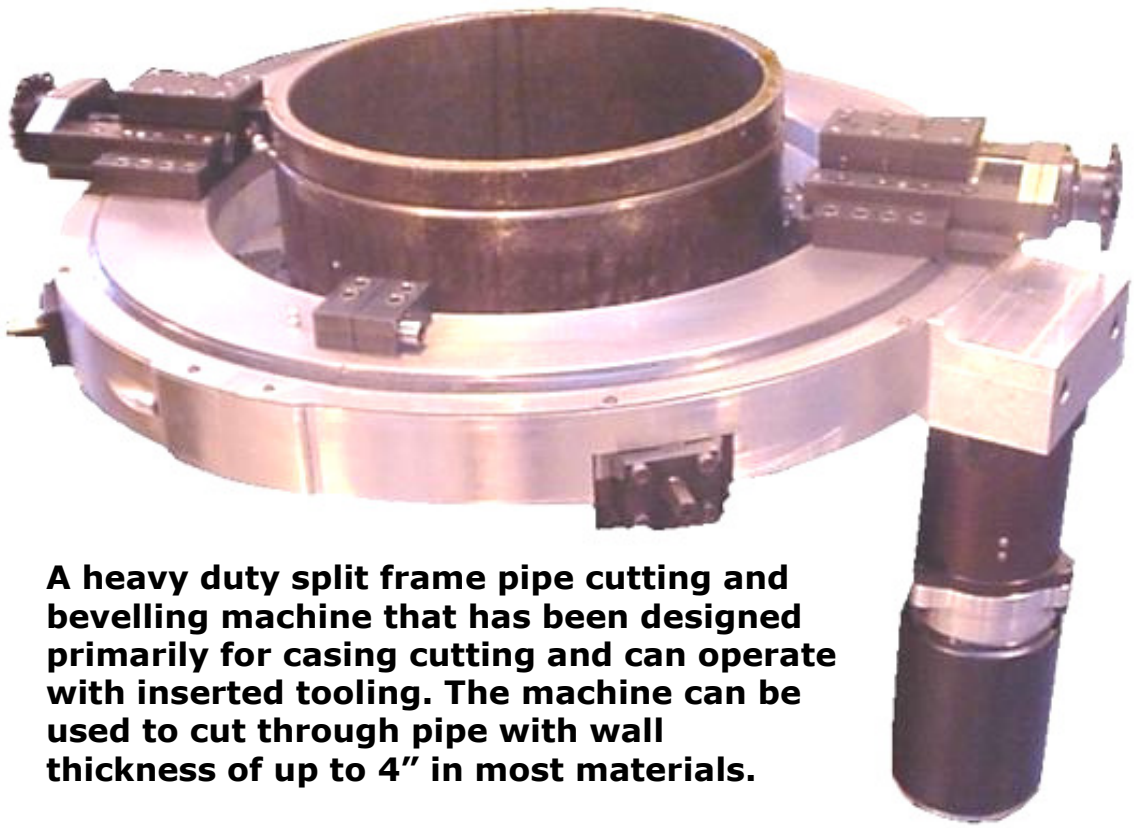

A heavy duty split frame pipe cutting and bevelling machine that has been designed primarily for casing cutting and can operate with inserted tooling. The machine can be used to cut through pipe with wall thickness of up to 4" in most materials.

- ***Heavy duty split frame design***
- ***Adjustable preloaded bearing track***
- ***Low height adjustable cutting toolboxes***
- ***Air or hydraulic drive***
- ***Counter boring unit (optional)***
- ***All operations in carbon steel, stainless steel, hastelloy and Incolloy***

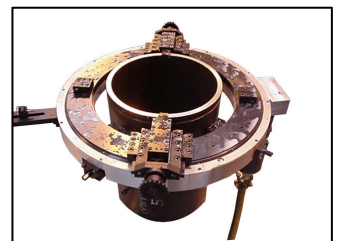
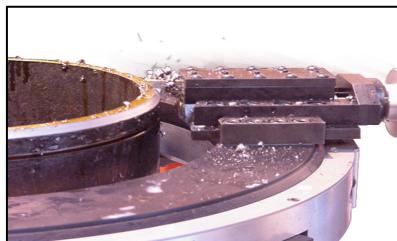
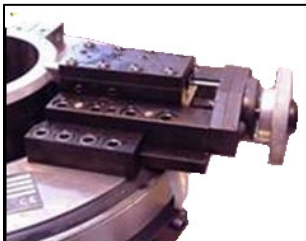

MSF Technical Details

MIRAGE

Machine Dimensions

Model	Size Range		A	B	C	D	Drive Options	
MSF300	100 - 300	4 - 12	315	445	75	125	3.2hP - 115mm	1.5Hp - 221mm
MSF400	200 - 400	8 - 16	415	545	75	125	3.2hP - 115mm	1.5Hp - 221mm
MSF500	300 - 500	12 - 20	515	645	75	125	5.4Hp - 175mm	3.5Hp - 290mm
MSF700	500 - 700	20 - 28	725	855	75	125	5.4Hp - 175mm	3.5Hp - 290mm
MSF900	600 - 915	28 - 36	925	1055	75	125	5.4Hp - 175mm	3.5Hp - 290mm
MSF1100	915 - 1100	36 - 42	1110	1260	75	125	5.4Hp - 175mm	3.5Hp - 290mm
MSF1220	1000 - 1220	40 - 48	1230	1380	75	125	5.4Hp - 175mm	3.5Hp - 290mm

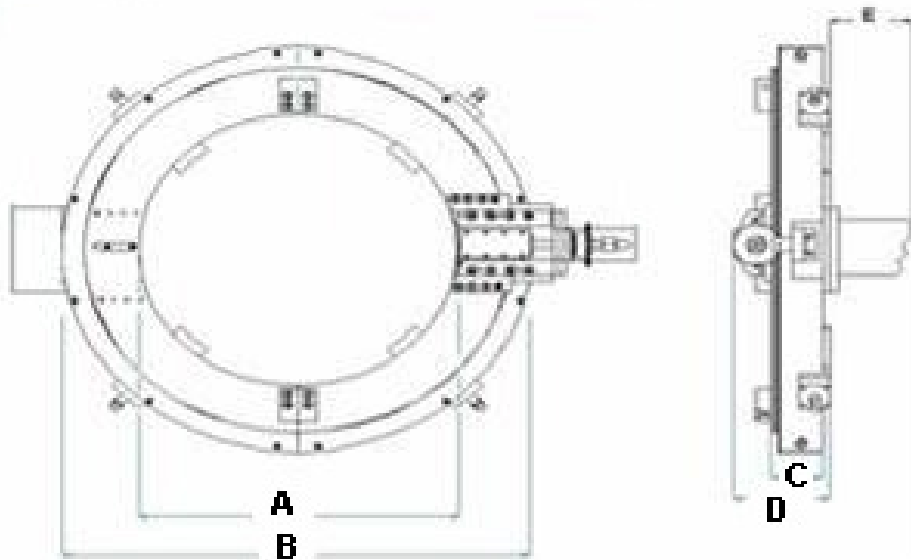

Machine Weights

Machine	Machine weight	Shipping weight	Length mm	Width mm	Height mm
MSF300	48 Kgs	85 Kgs	700	700	240
MSF400	55 Kgs	95 Kgs	800	800	300
MSF500	65 Kgs	100 Kgs	900	750	300
MSF700	75 Kgs	120 Kgs	1000	800	300
MSF900	198 Kgs	230 Kgs	1100	1000	400
MSF1100	205 Kgs	260 Kgs	1150	1150	400
MSF1220	205 Kgs	260 Kgs	1250	1250	400

The machine is supplied complete with 1 off split half drive ring, gearbox and drive motor, 2 off cutting / bevel toolboxes, striker feed unit with adjustable cut feature, 2 off Part off tools (Lead & follow), 2 off 37° bevel tools, integral clamping unit and spacers, toolkit including air filter lubricator and hose connection (when required), storage / shipping box, CE certificate, Packing list and Manual

10 Enterprise Way, Jubilee Parkway. DERBY DE21 4BB. UK

Tel: +44 (0)1332 291767 Fax: +44 (0)1332 370356

Email: sales@miragemachines.com www.miragemachines.com

MIRAGE
MACHINES