

MR1000 (40") Milling machine

32" stroke

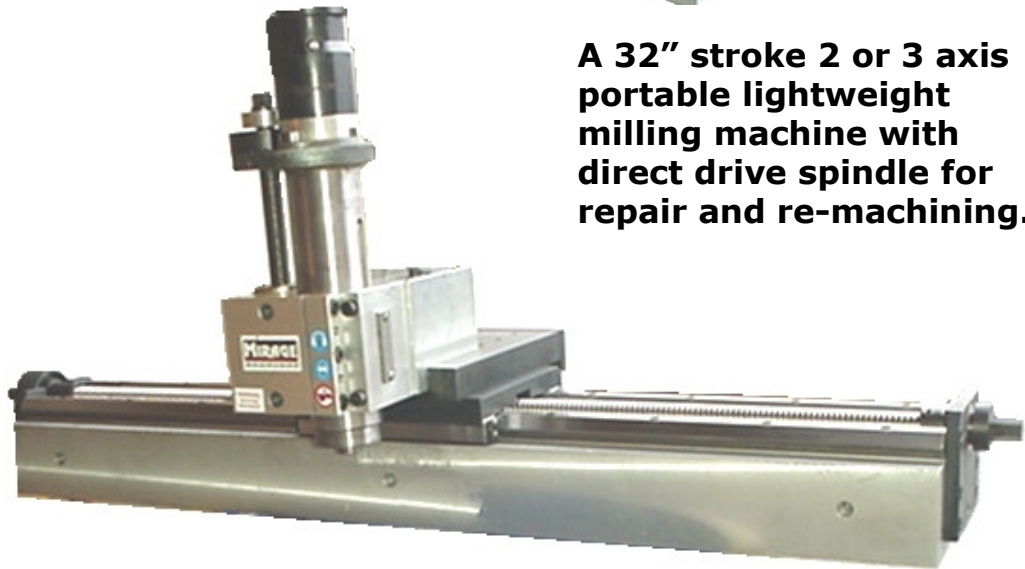

A 32" stroke 2 or 3 axis portable lightweight milling machine with direct drive spindle for repair and re-machining.



- ***Induction hardened 'V' slides***
- ***Turcite coated slideways***
- ***Ball screw feed***
- ***Quill type spindle – direct drive***
- ***2 or 3 Axis mounting***
- ***Optional auto feed available***

MR1000 Technical Details

MIRAGE

RANGE		
Maximum stroke	800mm	32"
Maximum cutter diameter	150mm	6"
Maximum spindle down feed	90mm	3.5"
Drive - pneumatic	1.5 Hp	1.11 Kw
Drive - hydraulic	2.2 Hp	1.64 Kw
Spindle R.P.M	Min: 50	Max: 640
Feed - Hydraulic @ 1050 psi (70 bar)	2.2 Hp	1.64 Kw
Feed - Pneumatic @ 90 p.s.i (6 bar)	0.9 Hp	0.67 Kw
Hydraulic supply @ 1050 psi (70 bar)	50 L/min	13 gal/min
Air Consumption / supply required	98 s.c.f.m	2.42 m3/m

FEED RATES		
Hand feed	5mm /rev	0.197"/rev
Auto feed standard motor supply	0 - 83mm/min	0 - 3.25"/min

WEIGHTS AND DIMENSIONS		
Machine weight	68 kgs	150 lbs
Shipping weight	96 Kgs	211 lbs

Shipping dimensions	L - 124cm - (49")	W- 39cm (15")	H- 36cm (14")
---------------------	-------------------	---------------	---------------

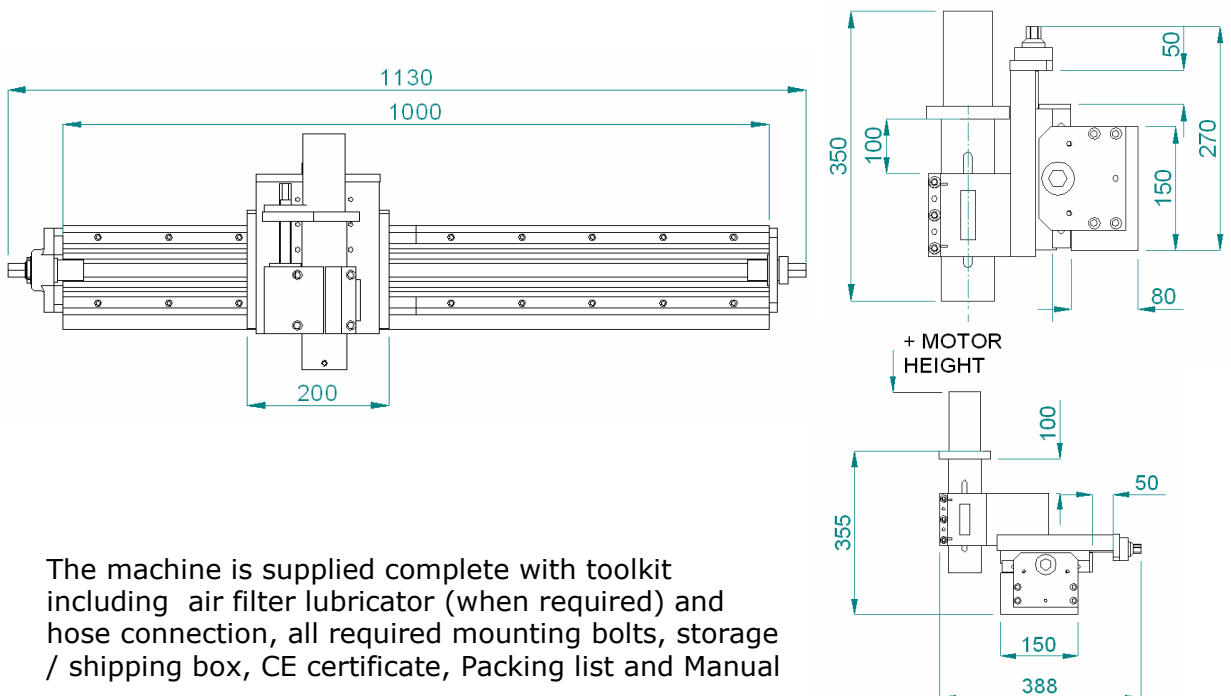

The machine is supplied complete with toolkit including air filter lubricator (when required) and hose connection, all required mounting bolts, storage / shipping box, CE certificate, Packing list and Manual

10 Enterprise Way, Jubilee Parkway. DERBY DE21 4BB UK

Tel: +44 (0)1332 291767 Fax: +44 (0)1332 370356

Email: sales@mirage-machines.co.uk www.mirage-machines.co.uk

