

MM300E (0 - 12") Flange Facer

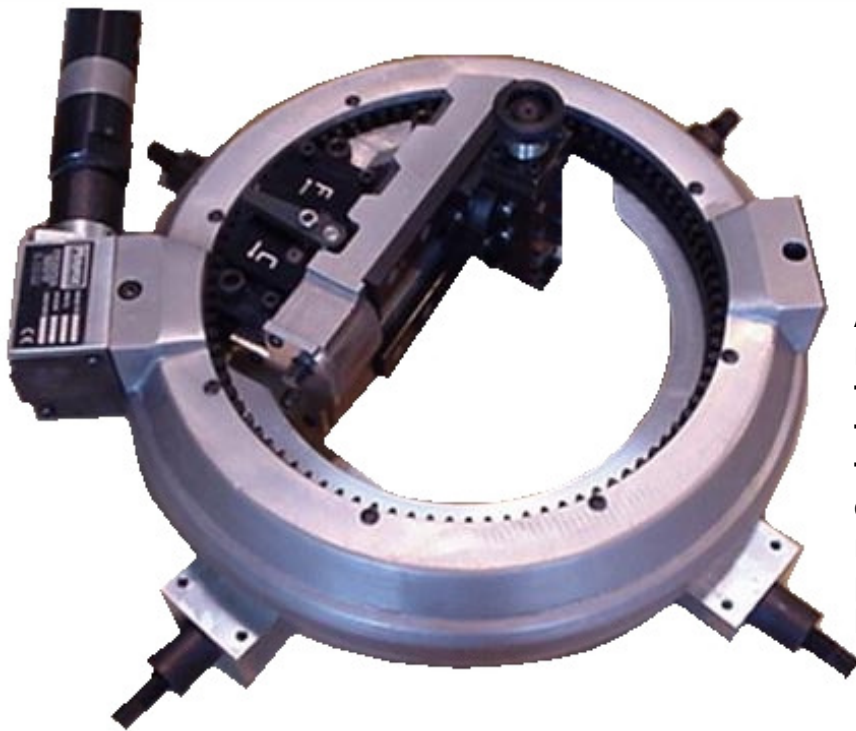

An externally mounted flange facing machine for all types of flange facing, seal groove machining, weld prep and counter boring

- ***Hardened dovetail slides***
- ***Lightweight precision construction***
- ***Preloaded cross roller drive ring***
- ***Geared facing and striker boring feeds***
- ***Swivel tool post***
- ***Helical drive for superior surface finish***
- ***Quick set independent base***



RTJ 'V' GROOVES

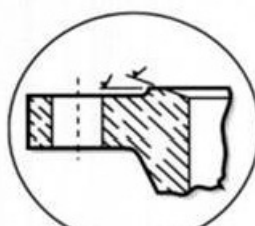

'LENS' RING

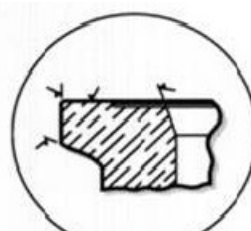

PROFILE GROOVES

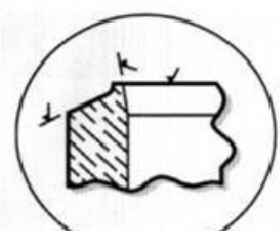

WELD PREPS

MIRAGE

MM300E Technical Details

MIRAGE

RANGE		
Minimum Facing diameter	0mm	0"
Maximum Facing diameter	305mm	12"
Minimum Clamping diameter	50mm	2"
Maximum Clamping diameter	305mm	12"
Tool post travel	75mm	3"
R.P.M	Min: 15	Max: 33
Drive - Pneumatic @ 90 p.s.i (6 bar)	0.9 Hp	0.67 Kw
Air Consumption / supply required	42 s.c.f.m	1.19 m3/m

FEED RATES		
Facing feeds (1.75mm pitch feed screw)	0.24 / 0.96mm	0.009 / 0.038"
Facing feeds (1.25mm pitch feed screw)	0.20 / 0.80mm	0.008 / 0.032"
Facing feeds (1.0mm pitch feed screw)	0.18 / 0.72mm	0.007 / 0.028"

WEIGHTS AND DIMENSIONS		
Machine weight (independent base 14kgs)	44 kgs	97 lbs
Shipping weight	70 kgs	154 lbs

Shipping dimensions	L - 53cm - (21")	W- 53cm (21")	H- 25cm (10")
---------------------	------------------	---------------	---------------

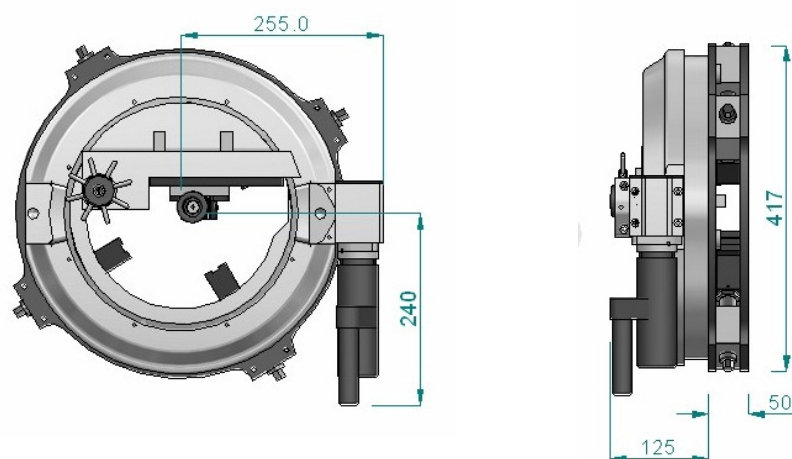

The machine is supplied complete with toolkit including tools and inserts, air filter lubricator and hose connection, all required mounting bases and extensions, storage / shipping box, CE certificate, Packing list and Manual

10 Enterprise Way, Jubilee Parkway. DERBY DE21 4BB. UK

Tel: +44 (0)1332 291767 Fax: +44 (0)1332 370356

Email: sales@miragemachines.com www.miragemachines.com

