

MiniMill – keyway Milling machine

2 - 20" diameters

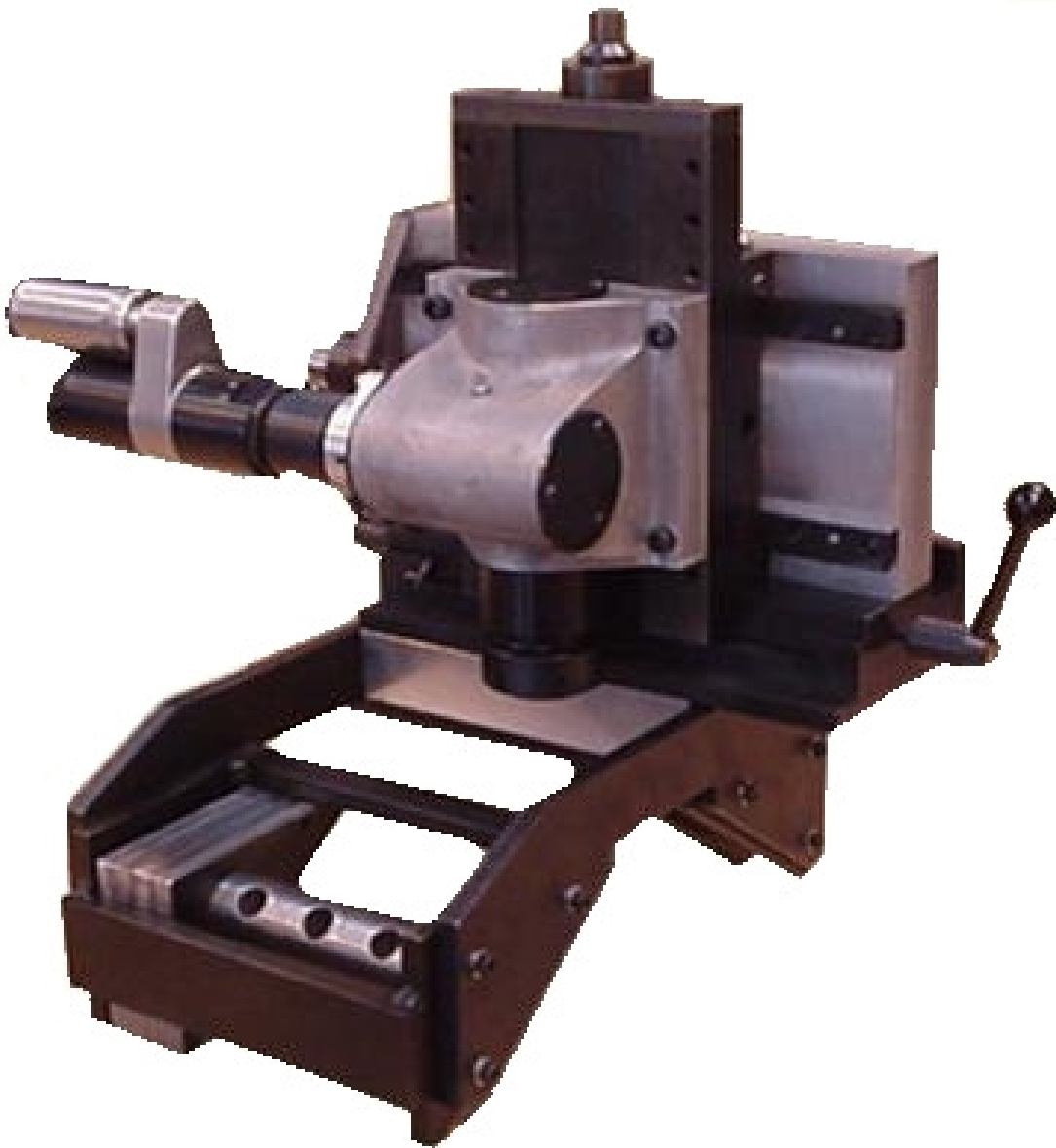

- ***Induction hardened 'V' slides***
- ***Turcite coated slideways***
- ***Quill type spindle – direct drive***
- ***3 Axis machining***
- ***Optional auto feed available***

MiniMill Technical Details

RANGE

Maximum stroke X	200mm	8"
Maximum stroke Y	40mm	1.5"
Maximum spindle down feed	50mm	2"
Drive - pneumatic	0.9 Hp	0.67 Kw
Drive - hydraulic	2.2 Hp	1.64 Kw
Spindle R.P.M	Min: 320	Max: 640
Feed - Hydraulic @ 1050 psi (70 bar)	2.2 Hp	1.64 Kw
Feed - Pneumatic @ 90 p.s.i (6 bar)	0.9 Hp	0.67 Kw
Hydraulic supply @ 1050 psi (70 bar)	50 L/min	13 gal/min
Air Consumption / supply required	98 s.c.f.m	2.42 m3/m

FEED RATES

Hand feed	2mm /rev	0.078"/rev
Auto feed standard motor supply	0 - 83mm/min	0 - 3.25"/min

WEIGHTS AND DIMENSIONS

Machine weight (base additional 15kg)	50 kgs	110 lbs	
Shipping weight	85 Kgs	187 lbs	
Shipping dimensions	L - 58cm - (23")	W- 56cm (22")	H- 48cm (19")

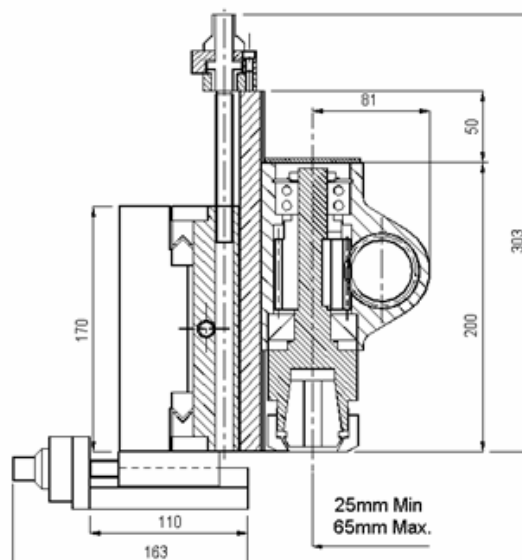

The machine is supplied complete with toolkit including air filter lubricator (when required) and hose connection, all required mounting bolts, storage / shipping box, CE certificate, Packing list and Manual

10 Enterprise Way, Jubilee Parkway. DERBY DE21 4BB UK

Tel: +44 (0)1332 291767 Fax: +44 (0)1332 370356

Email: sales@mirage-machines.co.uk www.mirage-machines.co.uk



MIRAGE