

IWG400 Internal Weld Grinding

Ø12 - 16" capacity

A portable internal 75mm wide belt grinding machine for removing internal welds from pipelines. .

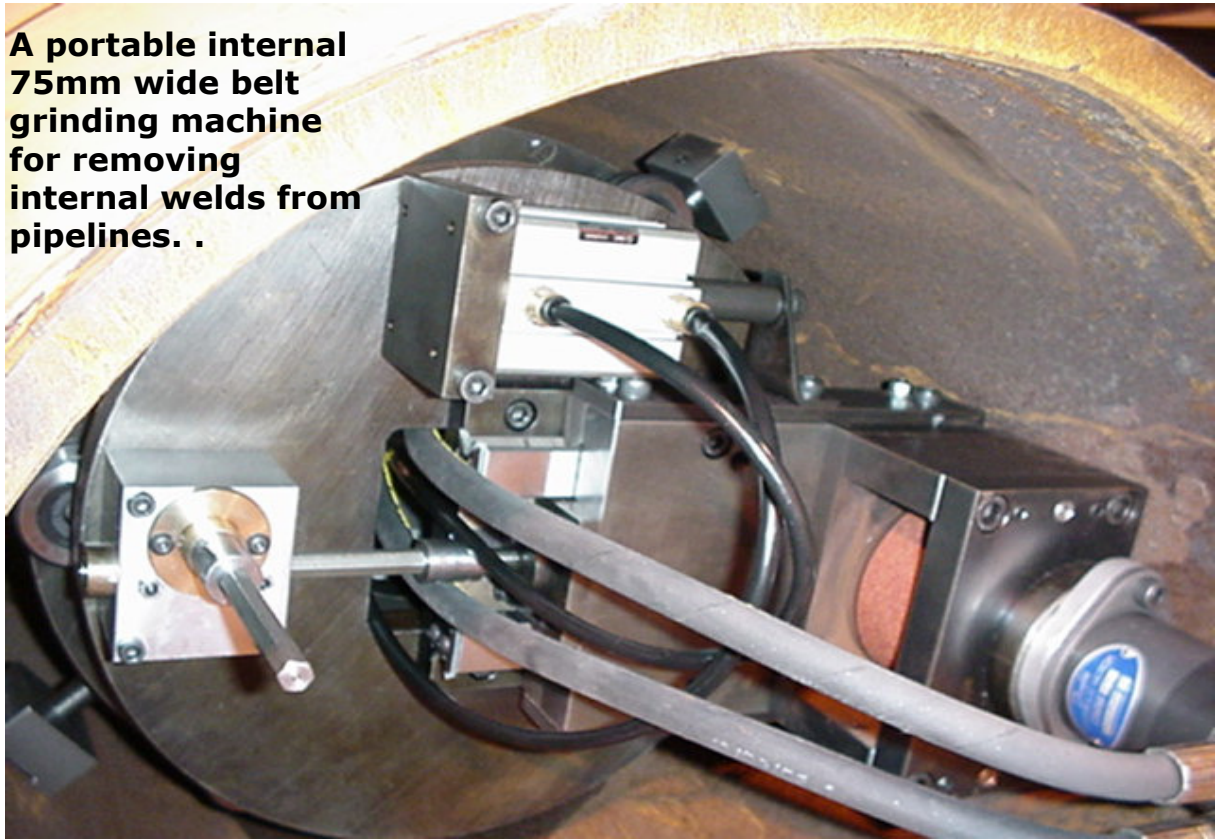

- ***Reduction geared drive.***
- ***High metal removal belt grinding***
- ***Out of round compensation rollers***
- ***Out of alignment swivel head***
- ***Hydraulic clamping chuck***
- ***Trolley for remote access***

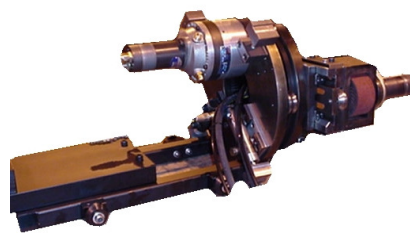

IWG400 Technical Details

MIRAGE

RANGE		
Minimum Pipe diameter	305mm	12"
Maximum Pipe diameter	410mm	16"
Spindle travel (compensating rollers)	50mm	2"
Spindle R.P.M	Min: 500	Max: 1200
Rotation R.P.M	Min: 0.25	Max: 10
Standard guide rod depth	3000mm	10 ft
Air supply Min: - compensating rollers	5 bar	70 psi
Drive - Hydraulic (weight + 6 kgs)	5.0 Hp	3.73 Kw
Hydraulic supply required @ 1050 p.s.i	40 L/min	9 gal/min

FEED RATES		
Feed rate - Manual / revolution	1mm	0.039"

WEIGHTS AND DIMENSIONS		
Machine weight	80 kgs	176 lbs
Shipping weight	120 Kgs	164 lbs

Shipping dimensions	L - 100cm - (40")	W- 40cm (16")	H- 40cm (16")
---------------------	-------------------	---------------	---------------

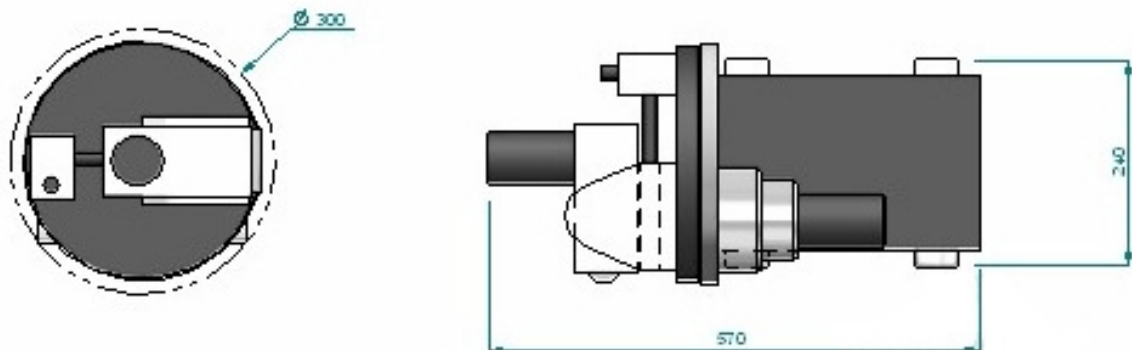

The machine is supplied complete with toolkit, air filter lubricator (when required) and hose connection, all required clamping pads and nuts, storage / shipping box, CE certificate, Packing list and Manual

10 Enterprise way, Jubilee Parkway. DERBY DE21 4BB. UK

Tel: +44 (0)1332 291767 Fax: +44 (0)1332 370356

Email: sales@mirage-machines.co.uk www.mirage-machines.co.uk

