

HT60 Portable Drill

17" stroke – Ø6" capacity



An versatile portable drilling and boring machine for heavy duty drilling and stud removal applications. The machine can be bolted directly to the work piece or have our new optional switch magnet base.

- ***4 leg heavy duty construction***
- ***5MT or 50 ISO centre fed spindle***
- ***Available with switch magnet base***
- ***Auto feed gearbox and motor***

HT60 Technical Details

RANGE		
Maximum Hole diameter (through base)	104mm	4"
Standard stroke	450mm	17"
Maximum stroke available (optional)	800mm	31.5"
R.P.M – air 3.5hp or 5.0hp hydraulic	Min: 15	Max: 74
Drive – Pneumatic @ 6 bar (90 p.s.i)	3.5 Hp	1.11 Kw
Drive – Hydraulic @ 70 bar (1050 p.s.i)	5.0 Hp	3.73 Kw
Feed – Pneumatic @ 6 bar (90 p.s.i)	0.9 Hp	0.67 Kw
Feed – hydraulic @ 70 bar (1050 p.s.i)	2.2 Hp	1.64 Kw
Air consumption required	98 s.c.f.m	2.69 m3/m
Hydraulic supply required	40 L/min	8.8 gal/min

FEED RATES		
Hand feed (Feed / revolution)	2.5mm	0.100"
Variable auto feed (optional)	0 – 20 mm/min	0 - 0.75"/min

WEIGHTS AND DIMENSIONS		
Machine weight (including 10kg auto feed)	87 kgs	191 lbs
Shipping weight	123 Kgs	270 lbs

Shipping dimensions	L - 145cm - (57")	W- 39cm (15")	H- 46cm (18")
---------------------	-------------------	---------------	---------------

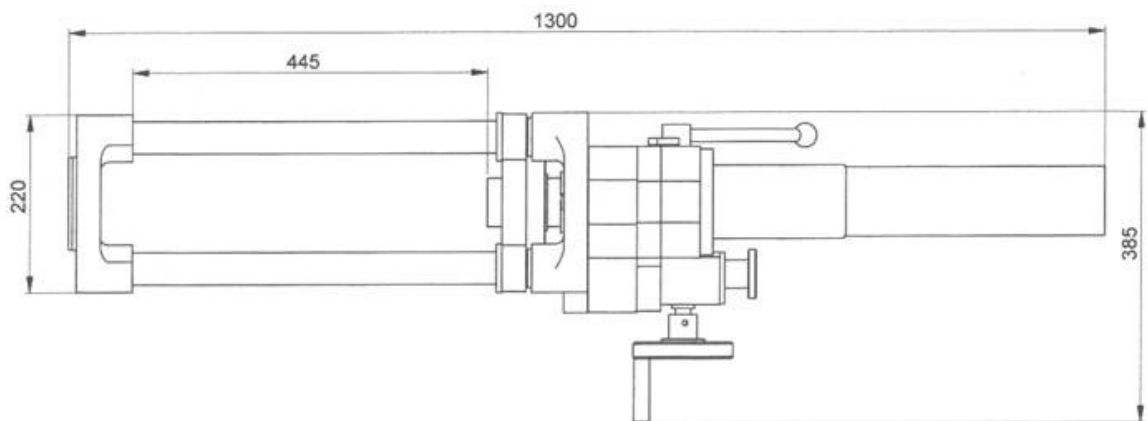

The machine is supplied complete with toolkit, air filter lubricator (when air driven) and hose connection, storage / shipping box, CE certificate, Packing list and Manual

10 Enterprise Way, Jubilee Parkway. DERBY DE21 4BB. UK

Tel: +44 (0)1332 291767 Fax: +44 (0)1332 370356

Email: sales@mirage-machines.co.uk www.mirage-machines.co.uk