

## HT40 Portable Drill

16" stroke – Ø3" capacity



A versatile portable drilling and boring machine for general drilling and stud removal applications. The machine can be bolted directly to the work piece or have our new optional switch magnet base.

- ***Linear rails & guides – accuracy and high load carrying capacity***
- ***40 ISO spindle accepts world wide standard tooling up to 4 MT***
- ***Helical geared spindle drive***
- ***Available with switch magnet base***
- ***Optional auto feed gearbox and motor***

## HT40 Technical Details

RANGE		
Maximum Hole diameter (through base)	100mm	4"
Standard stroke	405mm	16"
Maximum stroke available (optional)	800mm	31.5"
R.P.M – air 3.5hp or 5.0hp hydraulic	Min: 15	Max: 74
Drive – Pneumatic @ 6 bar (90 p.s.i)	3.5 Hp	1.11 Kw
Drive – Hydraulic @ 70 bar (1050 p.s.i)	5.0 Hp	3.73 Kw
Feed – Pneumatic @ 6 bar (90 p.s.i)	0.9 Hp	0.67 Kw
Feed – hydraulic @ 70 bar (1050 p.s.i)	2.2 Hp	1.64 Kw
Air consumption required	98 s.c.f.m	2.69 m3/m
Hydraulic supply required	40 L/min	8.8 gal/min

FEED RATES		
Hand feed (Feed / revolution)	2.5mm	0.100"
Variable auto feed (optional)	0 – 20 mm/min	0 - 0.75"/min

WEIGHTS AND DIMENSIONS		
Machine weight (including 10kg auto feed)	43 kgs	95 lbs
Shipping weight	72 Kgs	158 lbs

Shipping dimensions	L - 104cm - (40")	W- 39cm (14")	H- 44cm (14")
---------------------	-------------------	---------------	---------------

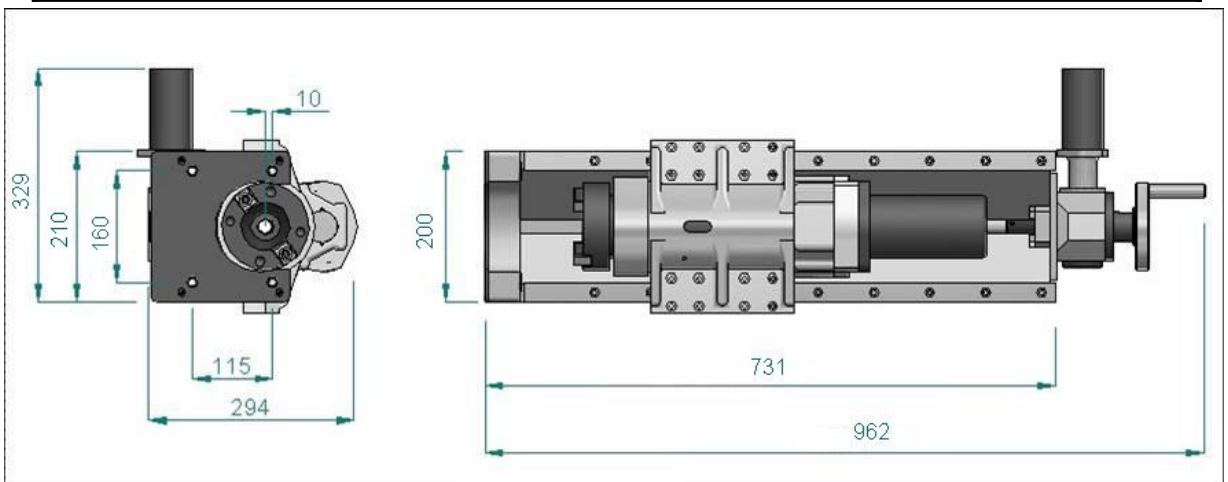

The machine is supplied complete with toolkit, air filter lubricator ( when air driven) and hose connection, storage / shipping box, CE certificate, Packing list and Manual

10 Enterprise Way, Jubilee Parkway. DERBY DE21 4BB. UK

Tel: +44 (0)1332 291767 Fax: +44 (0)1332 370356

Email: [sales@mirage-machines.co.uk](mailto:sales@mirage-machines.co.uk) [www.mirage-machines.co.uk](http://www.mirage-machines.co.uk)