

## HT20 Portable Drill

12" stroke – Ø2" capacity



A versatile portable drilling and boring machine for general drilling and stud removal applications. The machine can be bolted directly to the work piece or have our new optional switch magnet base.

- ***Linear rails & guides – accuracy and high load carrying capacity***
- ***3MT spindle accepts standard tooling***
- ***Direct spindle drive***
- ***Available with switch magnet base***
- ***Optional auto feed gearbox and motor***

## HT20 Technical Details

RANGE		
Maximum Hole diameter (through base)	50mm	2"
Standard stroke	305mm	12"
Maximum stroke available (optional)	500mm	20"
R.P.M – air 3.5hp or 5.0hp hydraulic	Min: 15	Max: 100
Drive – Pneumatic @ 6 bar (90 p.s.i)	3.5 Hp	1.11 Kw
Drive – Hydraulic @ 70 bar (1050 p.s.i)	5.0 Hp	3.73 Kw
Feed – Pneumatic @ 6 bar (90 p.s.i)	0.9 Hp	0.67 Kw
Feed – hydraulic @ 70 bar (1050 p.s.i)	2.2 Hp	1.64 Kw
Air consumption required	98 s.c.f.m	2.69 m3/m
Hydraulic supply required	40 L/min	8.8 gal/min

FEED RATES		
Hand feed (Feed / revolution)	2.5mm	0.100"
Variable auto feed (optional)	0 – 20 mm/min	0 - 0.75"/min

WEIGHTS AND DIMENSIONS			
Machine weight (including 10kg auto feed)	25 kgs	55 lbs	
Shipping weight	45 Kgs	100lbs	
Shipping dimensions	L - 76cm - (30")	W- 28cm (11")	H- 28cm (11")

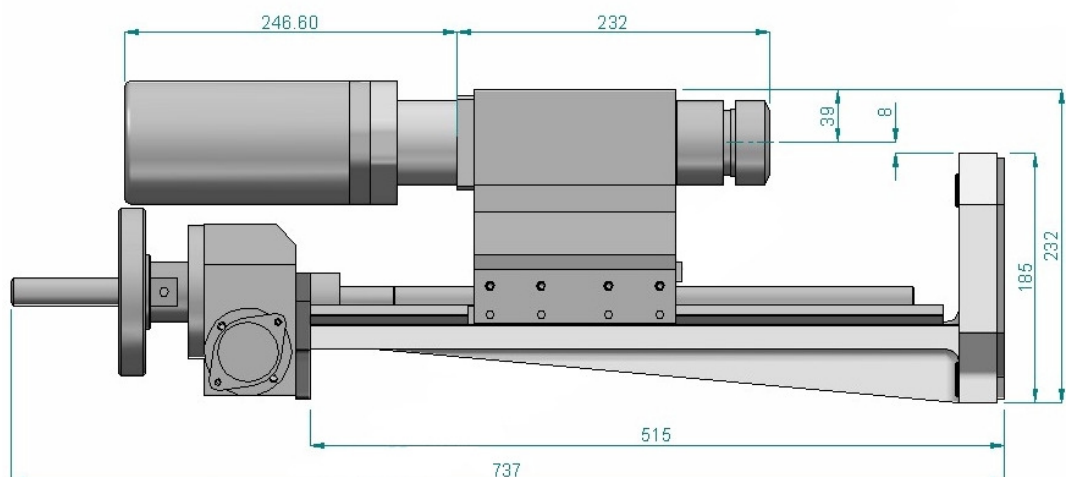

The machine is supplied complete with toolkit, air filter lubricator ( when air driven) and hose connection, storage / shipping box, CE certificate, Packing list and Manual

10 Enterprise Way, Jubilee Parkway. DERBY DE21 4BB. UK

Tel: +44 (0)1332 291767 Fax: +44 (0)1332 370356

Email: [sales@mirage-machines.co.uk](mailto:sales@mirage-machines.co.uk) [www.mirage-machines.co.uk](http://www.mirage-machines.co.uk)